

# **HAND WRAPPER**

# **BAG NECK SEALER**

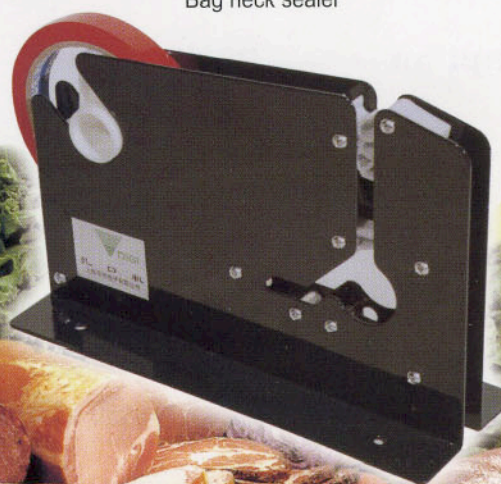

Hand wrapper



Bag neck sealer





# Convenience and hygiene

## Specification

- TEFLON coating on the surface of the film cutter and the heated board, easy to clean
- Space between heated board and packer body, avoid the body of packer to be heated
- Easy to use, high reliability

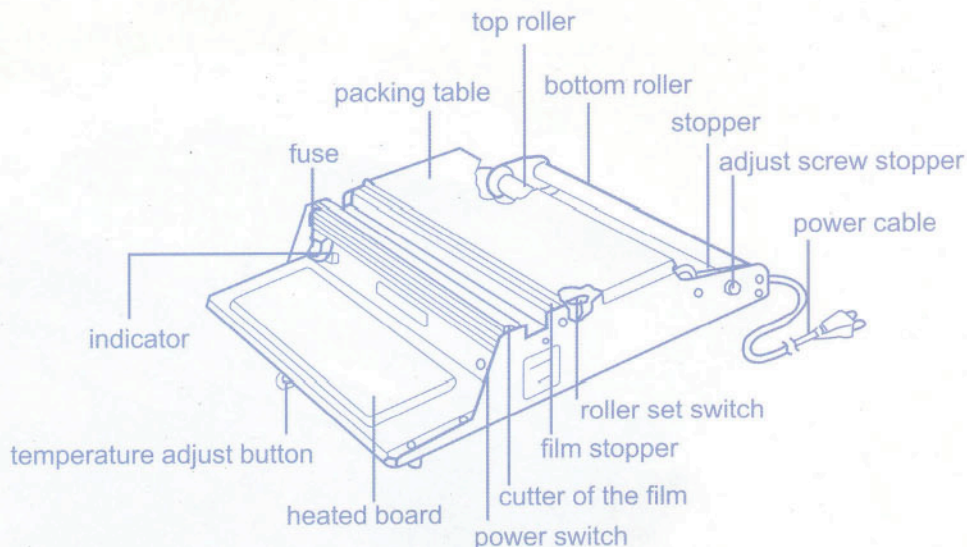

Name SA-11

Power source 220V

Power Consumption 200W

Weight 7kg

Width(max) 400mm

Material Galvanizing board,  
Stainless steel board

Dimensions 470(L)X585(W)X140(H)mm



\*Specifications are subject to change without notice.

**HUB'S** 合功成  
Quality Service Value



Certificate No. 100025

The Hub's Engineering Pte Ltd  
231 Ubi Avenue 4, Intrepid Warehouse Complex Singapore 408817  
Tel: (65) 6749 1911 Fax: (65) 6749 4476 Service Hotline: (65) 9007 0799  
Email: hubsales@hubs.com.sg